

S1U2 Installation Reference Guide

How to install S1U2 on terminal equipment.

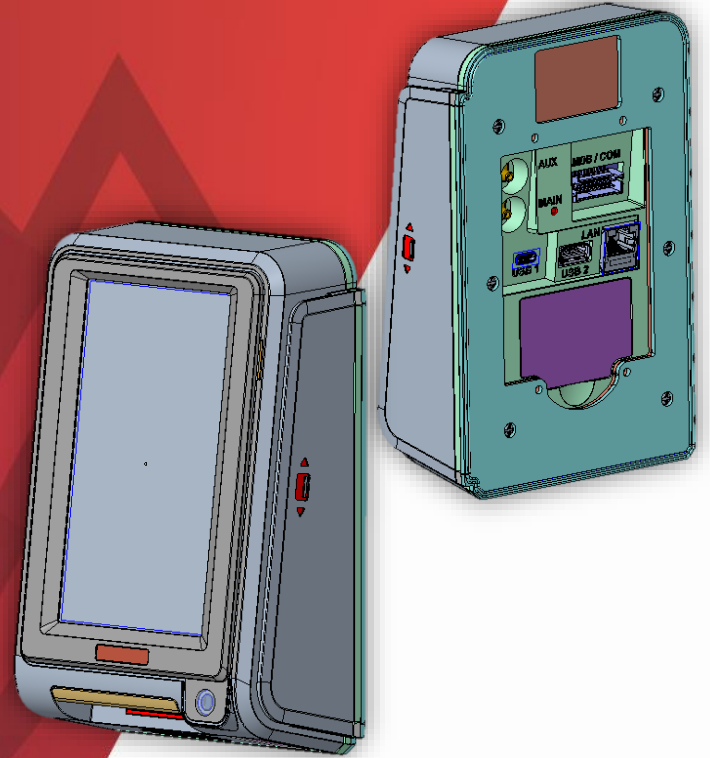

Product Size/Weight

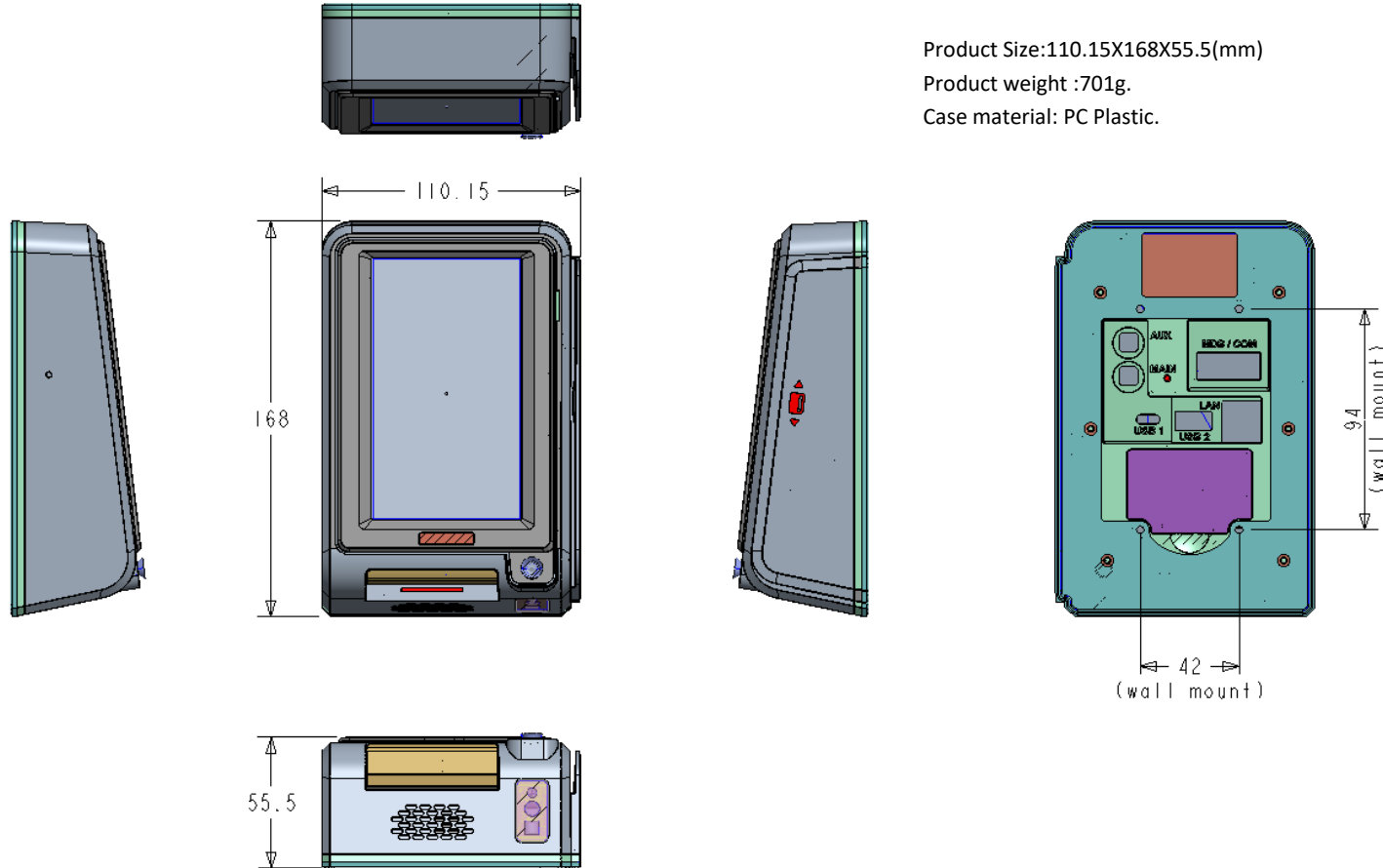

Product Waterproof and dustproof method

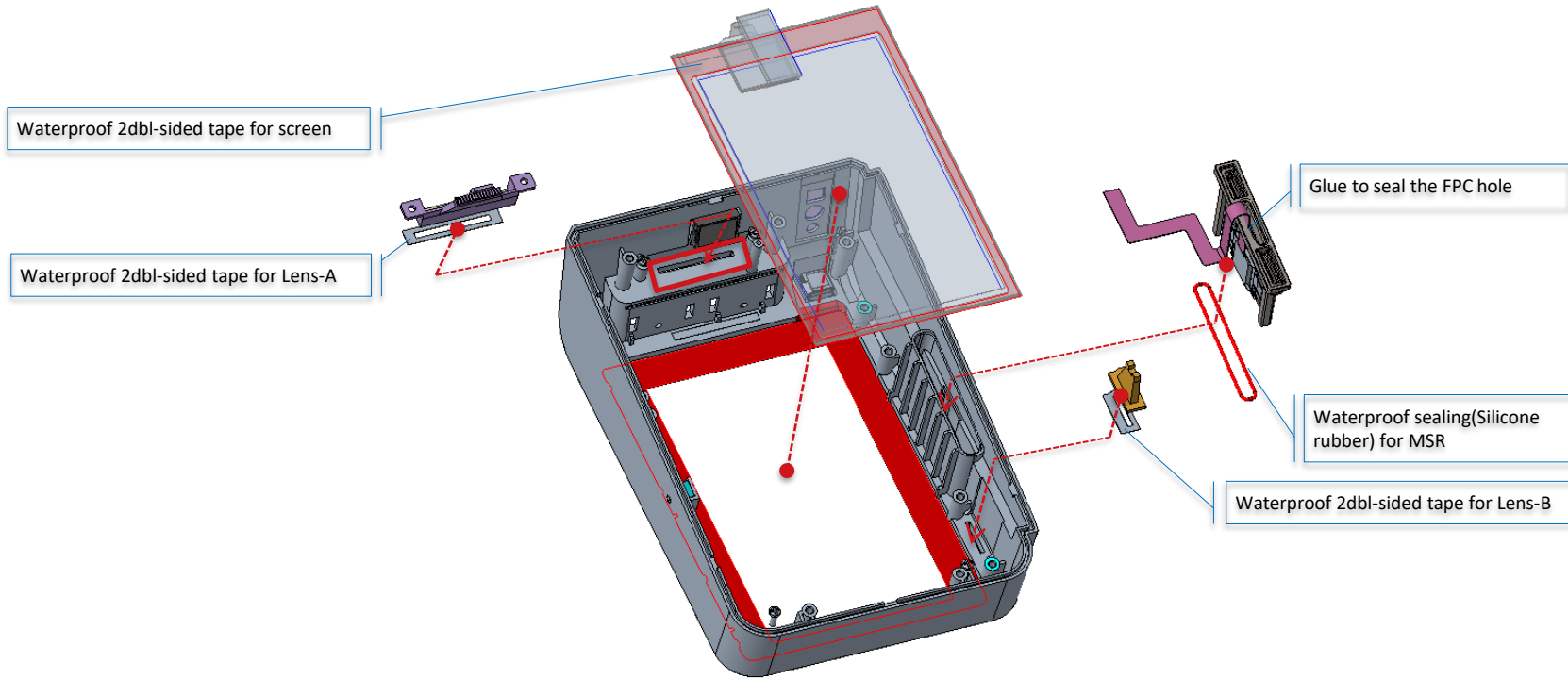

Waterproof Level:IP65

Product Waterproof and dustproof method

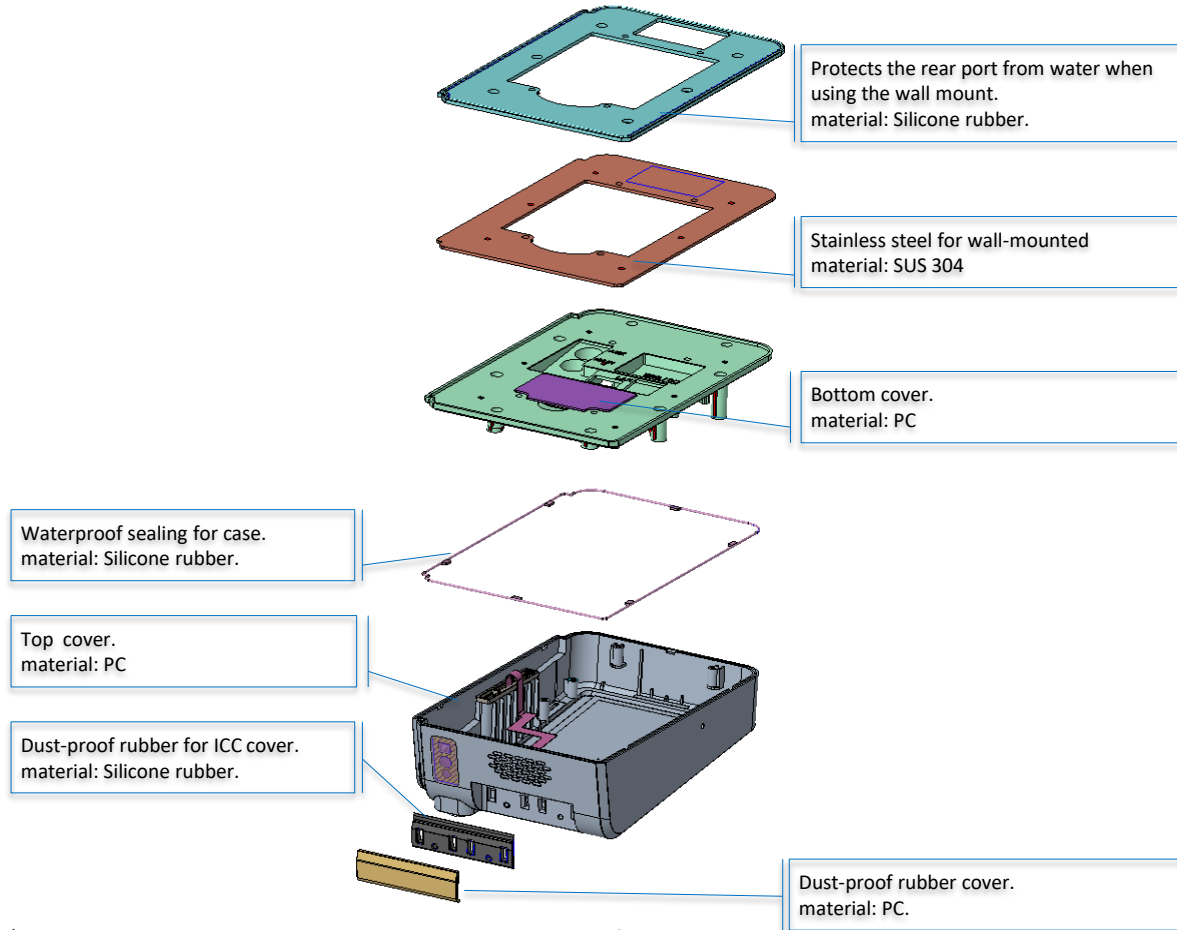

Waterproof installation of terminal equipment

- The green pad is made of silicon rubber. When mounted on the wall, make sure it is in close contact with the wall to prevent water from entering the unit.

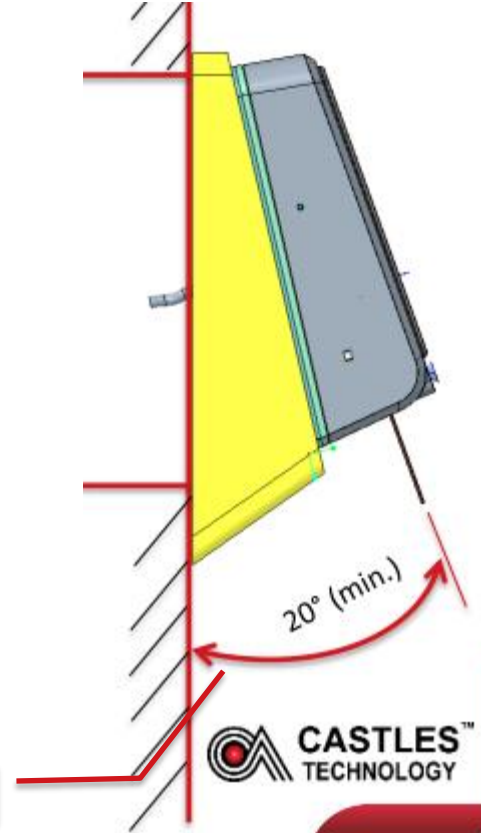
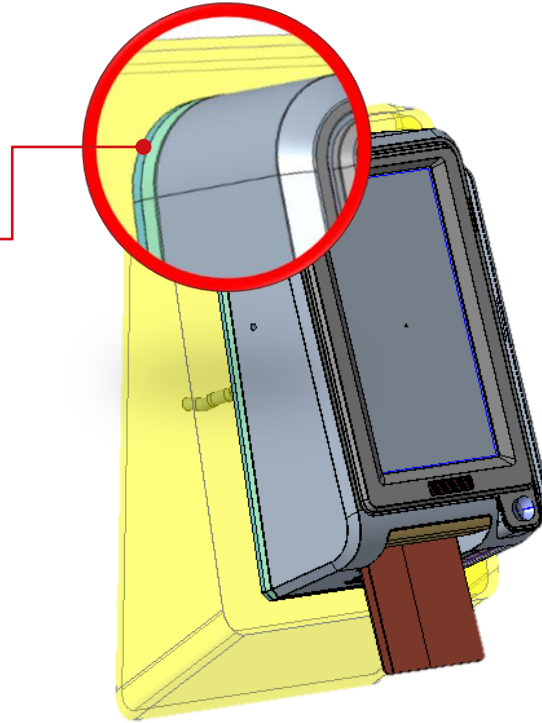
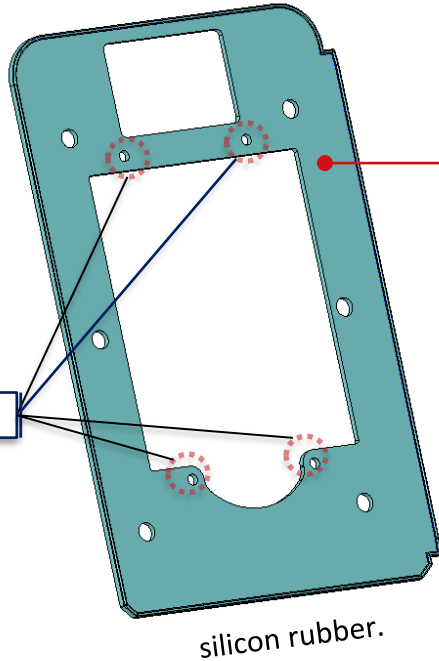

The recommended installation angle is 20 degrees.

Terminal Interface

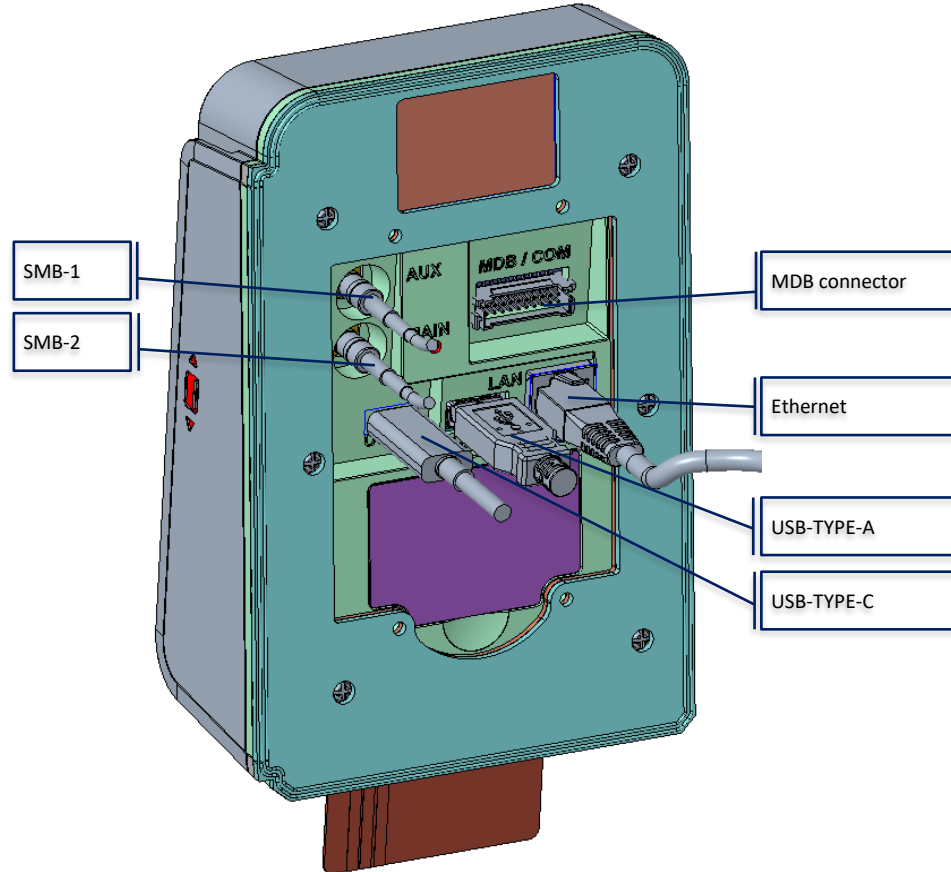

Easy Installation

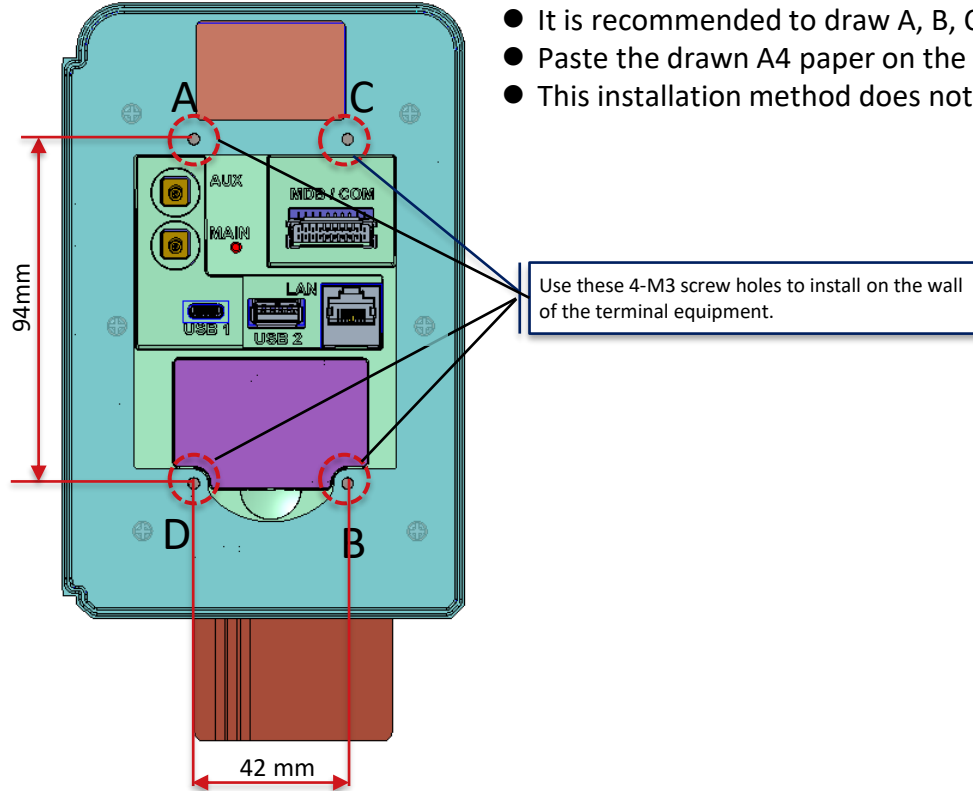

- It is recommended to draw A, B, C, D. 4 screw holes on a piece of A4 paper.
- Paste the drawn A4 paper on the installation plane to prepare for drilling.
- This installation method does not need to comply with the EVA specification

Installation of Terminal equipment

It is recommended to use 4-M4 rivets (according to EVA & NAMA specifications)

图纸:

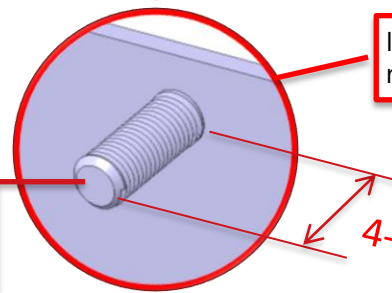
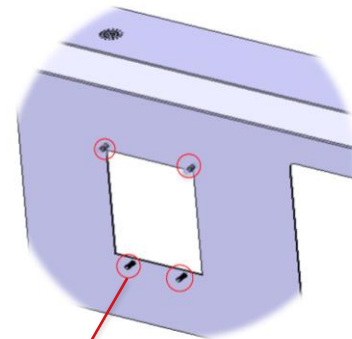
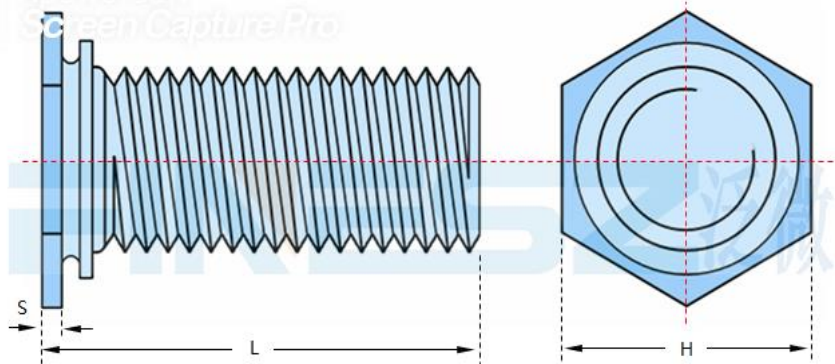

It is recommended to use 4-M4 rivets.

4-M4x10L

以下为公制规格的六角压铆螺母柱NFH NFHS的尺寸规格表:

螺距 Pitch	型号TYPE		螺 纹 代 号	长度 LENGTH CODE"L"±0.4 (LENGTH CODE IN 16THS OF AN INCH)										最 小 板 厚	板 孔 径	H ±0.4	S MAX	最 小 边 距
	碳 钢	不 锈 钢		6	8	10	12	15	18	20	25	30						
M3X0.5	NFH	NFHS	M3	6	8	10	12	15	18	20	25		1	4.8	6	1.25	5.4	
M4X0.7	NFH	NFHS	M4	6	8	10	12	15	18	20	25	30	1	4.8	6	1.25	7.2	
M5X0.8	NFH	NFHS	M5		8	10	12	15	18	20	25	30	1.2	5.0	6.35	1.25	7.2	
M6X1	NFH	NFHS	M6			10	12	15	18	20	25	30	1.6	6.0	7	1.4	7.9	

HEX NUTS&Hex. Nut

Installation of Terminal equipment

suitable for EVA standard door panel accessories dimensions.

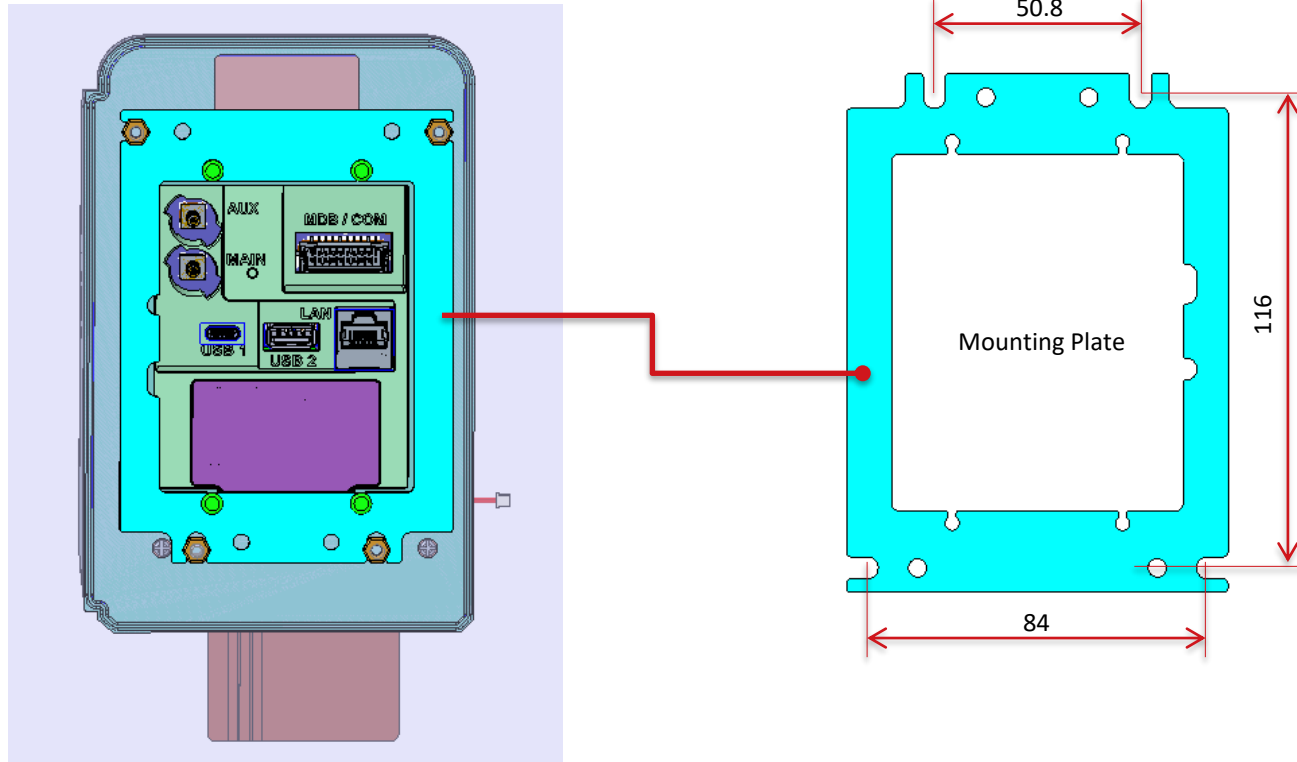

Thanks

